



SPECIFICATIONS MQ1364e

FEATURES

- Dedicated horn loaded MF/HF array module
- 10-in MF w/ Radial Phase Plug™; 2-in exit Neodymium HF
- 60° x 40° beamwidth
- Vertically configured to create horizontal arrays

DESCRIPTION

A dedicated mid/high system in a vented trapezoidal enclosure. Includes a horn-loaded 10-in MF cone with Radial Phase Plug™ and a 2-in exit/3-in diaphragm Neodymium compression driver. The MF and HF horns provide a nominal 60° x 40° beamwidth. An internal passive crossover with jumpers on the input panel allows user selection of either bi-amplified or passive operation. In either case digital signal processing is required to achieve specified performance. The enclosure features a comprehensive system of 3/8"-16 threaded suspension points.

APPLICATION

The MQ1364e employs a no-compromise design where the mid and high frequency horns are truly large enough to provide optimal pattern control throughout each passband. The horns feature a rigid but well-damped construction using wood veneer backed by structural foam. The MQ1364e has been designed to work with a complementary MQ1300 Series LF loudspeaker to create a full-range audio system, but may also be used without a LF complement for voice-only applications. The enclosure is vertically configured for arraying in horizontal rows. Horizontal arrays are typically used in venues, such as houses of worship, where the array must address wide, fan-shaped audiences.

Application Usage: Install

Houses of Worship	Auditoriums
Theatres	Arenas
Performing Arts Centers	Stadiums

PERFORMANCE

Frequency Response (1 W @ 1m)

±3 dB	250 Hz to 15 kHz
-10 dB	200 Hz

Axial Sensitivity (dB SPL, 1 Watt @ 1m)

Passive	109
MF	109
HF	108

Impedance (Ohms)

Passive	8
MF	8
HF	8

Power Handling, AES Standard (Watts)

Passive	325
MF	400
HF	150



Calculated Maximum Output (dB SPL)

Passive Peak	140
MF Peak	141
HF Peak	136
Passive Long Term	134
MF Long Term	135
HF Long Term	130

Nominal Coverage Angle/-6 dB points (degrees)

Horizontal	60
Vertical	40

Recommended High-Pass Frequency

24 dB/Octave	200 Hz
--------------	--------

PHYSICAL

Configuration	Mid/High
Powering	Passive or Bi-amplified
MF Subsystem	1x 10-in horn-loaded cone, Radial Phase Plug™
HF Subsystem	1x 2-in exit/3-in voice coil compression driver on constant directivity horn
Enclosure Materials	Exterior grade Baltic birch plywood
Finish	Wear resistant textured black paint
Connectors	Terminal barrier strip
Suspension Hardware	16x 3/8"-16 threaded mounting suspension points (4 each top, bottom and sides)
Grille	Powder coated perforated steel

Dimensions

	inches	millimeters
Height	40.00	1016
Width (front)	32.00	813
Width (rear)	8.12	206
Depth	25.61	650
Trapezoid Angle	25° per side	

Weights

	pounds	kilograms
Net Weight	148	67.3
Shipping Weight	156	70.9





SPECIFICATIONS MQ1364e

DIMENSIONAL DRAWING

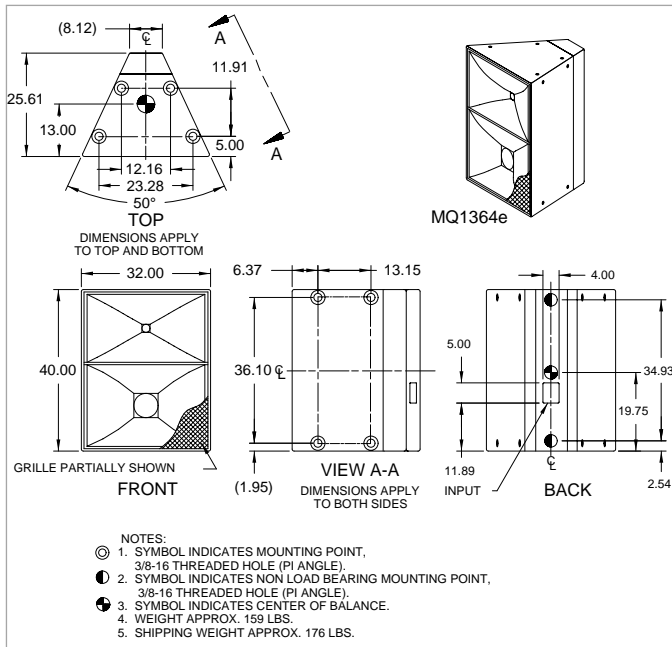

Manufacturing tolerances are +/- 0.13 and +/- 1°

A & E SPECIFICATIONS

The 2-way mid/high loudspeaker shall incorporate a 10-in MF cone with Radial Phase Plug™, and a 2-in exit/3-in diaphragm HF compression driver. The MF and HF devices shall be loaded on horns that provide a nominal 60° x 40° beamwidth. An internal passive crossover network shall offer either passive or bi-amplified operation, configurable via jumpers on the input panel.

System frequency response shall vary no more than 63 dB from 250 Hz to 15 kHz measured on axis. When amplified using the internal passive crossover network, the loudspeaker shall produce a sound pressure level of 109 dB SPL on axis at 1 meter with a power input of 1 watt, and shall be capable of producing a peak output of 140 dB SPL on axis at 1 meter. It shall handle 325 watts of amplifier power (AES Standard) and shall have a nominal impedance of 8 ohms. When bi-amplified, the MF section shall produce a sound pressure level of 109 dB SPL on axis at 1 meter with a power input of 1 watt, and shall be capable of producing a peak output of 141 dB SPL on axis at 1 meter. It shall handle 400 watts of amplifier power (AES Standard) and shall have a nominal impedance of 8 ohms. The HF section shall produce a sound pressure level of 108 dB SPL on axis at 1 meter with a power input of 1 watt, and shall be capable of producing a peak output of 136 dB SPL on axis at 1 meter. It shall handle 150 watts of amplifier power (AES Standard) and shall have a nominal impedance of 8 ohms.

The loudspeaker enclosure shall be trapezoidal in shape. It shall be constructed of exterior grade Baltic birch plywood and shall employ extensive internal bracing. It shall be finished in wear-resistant textured black paint. Input connectors shall be a terminal strip. A total of 16x 3/8"-16 threaded mounting/suspension points (4 each top, bottom, and sides) shall be provided. The front of the loudspeaker shall be covered with a powder coated perforated steel grille.

The 2-way mid/high loudspeaker shall be the EAW model MQ1364e.

